

**SUMMARY REPORT ON THE EVENTS AND ACTIONS OF THE NPPs AND THE CSN,  
FROM THE PERSPECTIVE OF NUCLEAR SAFETY AND RADIATION PROTECTION,  
DURING THE TOTAL LOSS OF ELECTRICAL POWER THAT OCCURRED ON 28 APRIL 2025**

April 2026

PUBLIC USE

## TABLE OF CONTENTS

1. PURPOSE.....	4
2. RESPONSE OF OPERATING NUCLEAR POWER PLANTS AND MAIN ACTIONS BY LICENSEES in response to the loss of external power .....	4
2.1 Electrical transient in the supply network.....	4
2.2 Response and actions of Spanish nuclear power plants to the total loss of external power .....	6
3. ACTIONS BY SPANISH THE NUCLEAR SAFETY COUNCIL .....	8
3.1 Activation of the emergency response organisation .....	8
3.2 Supervision by the CSN of the performance and operation of electrical systems at nuclear power plants during the pre-alert .....	9
3.3 Supervision of the licensees' actions by the CSN resident inspectors.....	10
4. CONCLUSIONS .....	12
ANNEX: Summary tables of the actions taken by the power plants .....	14

**This report does not assess or determine the causes of the total power loss incident that occurred on 28 April 2025, as this does not fall within the remit of the Nuclear Safety Council, which is limited to nuclear safety and radiation protection**

## ACRONYMS

A&E: Accident and Emergency  
ARI: Assistant Resident Inspector  
CAGE: Alternative Emergency Management Centre  
CAT: Technical Support Centre  
CECOP: Operational Coordination Centre  
CSN: Spanish Nuclear Safety Council  
DPR: CSN Technical Directorate for Radiation Protection  
DSN: CSN Technical Directorate for Nuclear Safety  
ETF: Technical Operating Specifications  
GDE: Emergency diesel generator  
GP: Main generator  
HPP: Hydroelectric Power Plant  
INES TEC: Institute for Systems and Computer Engineering, Technology and Science  
INRE: CSN Resident Inspectorate  
LPS: Total loss of external power supply  
MWe: Megawatts of electricity  
NPPs: Nuclear Power Plants  
ORE: Emergency Response Organisation  
PEI: On-site Emergency Plan  
PRS: Procedures for restoring service  
REE: Spanish Electricity Grid  
RHR: residual heat removal system  
RI: Resident Inspector  
SALEM: CSN Emergency Room  
SCN: CSN Nuclear Facilities Deputy-Directorate

## 1. PURPOSE

The purpose of this report is to summarise the response of operating nuclear power plants (NPPs) and the main actions taken by their licence holders following the total power loss incident that occurred on 28 April 2025, which affected the entire Iberian Peninsula. It also summarises the actions taken by the Spanish Nuclear Safety Council (CSN) during the incident, as well as the subsequent supervisory actions carried out by this organisation. The actions of the licence holders of other nuclear or radioactive facilities, nor those of the CSN associated with them, have not been included here.

It is not within the competences of the CSN to assess or determine the causes of the incident in the national electricity system; therefore, this report does not analyse those causes but only examines the response to the incident from the perspective of its impact on nuclear safety and radiation protection.

## 2. RESPONSE OF OPERATING NUCLEAR POWER PLANTS AND MAIN ACTIONS BY LICENSEES IN RESPONSE TO THE LOSS OF EXTERNAL POWER

### 2.1 Electrical transient in the supply network

The information contained in this section is drawn from public sources (INESCTEC, REE, etc.). This report does not evaluate this information; rather, it is used to provide a brief description of the associated operational events.

The total loss of electricity supply was caused by several transients in the transmission grid, which triggered trips in the generation chain, leading to a drop in grid frequency and a rise in voltage. This, in turn, caused cascading failures that affected all distribution networks, ultimately resulting in the collapse of the system at 12:33:24 on 28 April 2025.

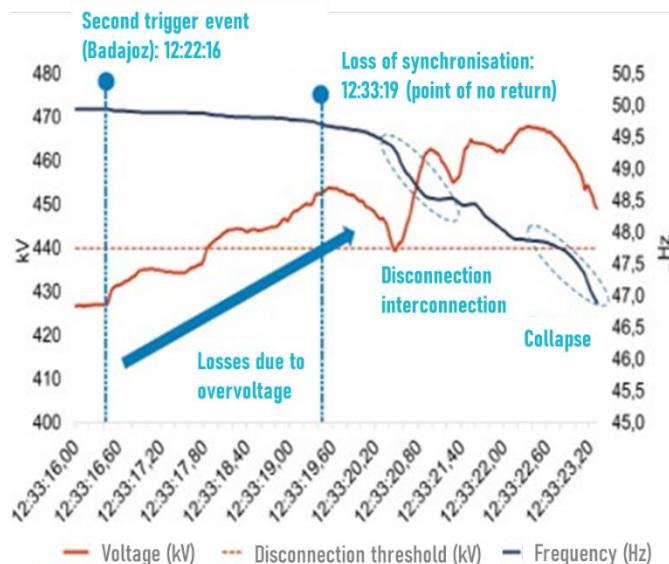

**Figure 1:** Evolution of frequency and voltage in the grid prior to the blackout (Source: Compass Lexecon-INESCTEC).

Electricity generation on 28 April, up to the moment the incident occurred, is shown in Figure 2, with total nuclear power generation remaining stable at an average of 3,387 MWe.

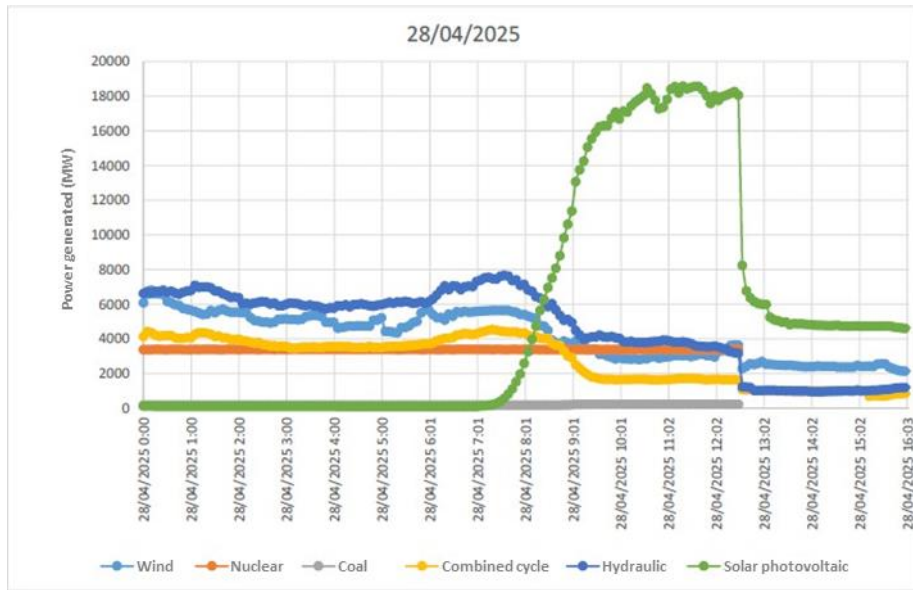

**Figure 2:** Electricity generation on 28 April 2025 (REE data)

On the morning of 28 April, visible voltage fluctuations were detected in the transmission grid, prompting Red Eléctrica Española, REE (Spanish Electricity Grid) to take certain measures to address these instabilities.

Subsequently, voltage began to rise linearly across the entire grid, coinciding with a sustained reduction in exports via the interconnection with France, which eventually shifted to an import-based mode. Due to the generalised increase in voltage, several transients occurred, characterised by trips in the generation chain. These chain disconnections of generation units reduced reactive power absorption, which contributed to overvoltage and a drop in frequency, which in turn caused, amongst other things, the disconnection of the CCNNs due to underfrequency.

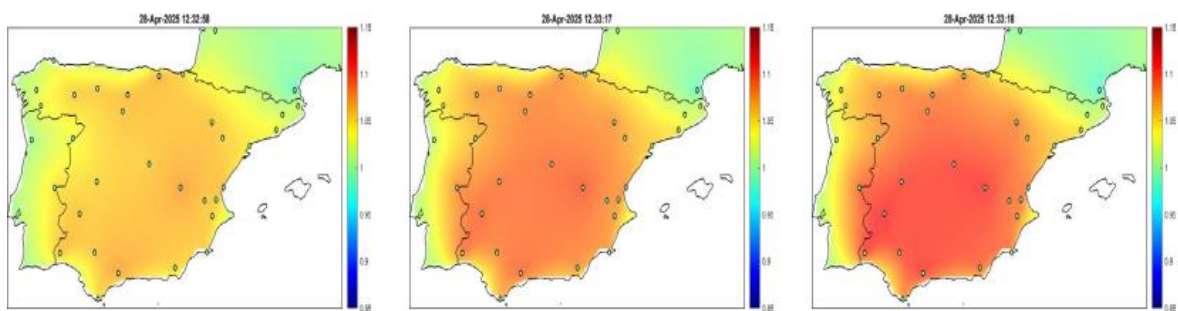

**Figure 3:** Dimensionless overvoltage contour map with reference voltage PU (a) 12:32:58, (b) 12:33:17, (c) 12:33:18 (Source: ENTSO-E)

## 2.2 Response and actions of Spanish nuclear power plants to the total loss of external power

The following table summarises the operational status of Spanish nuclear power plants prior to the incident:

Plant /Group	Operational status	Electrical power (MWe)
Almaraz I	Cold	-
Almaraz II	70%	680
Ascó I	70%	719
Ascó II	100%	1034
Cofrentes	Cold stop	-
Trillo	Refuelling	-
Vandellós II	100%	1089

Figure 4 shows a simplified diagram that conceptually illustrates the power supply to the loads in a nuclear power plant from the external power grid (in this example, 400 kV and 200 kV substations) or from the unit's own main generator, should the plant be operating at full power and supplying electricity to the grid. The power supply to the plant's consumers is provided to the so-called normal busbars and the safeguard (emergency) busbars. In the event of a failure in the external power supply, the emergency busbars are equipped with diesel generators that start up in response to low voltage or frequency signals at the busbars and connect to the relevant busbar to restore voltage there, thereby supplying the power required to maintain the plant in a safe condition.

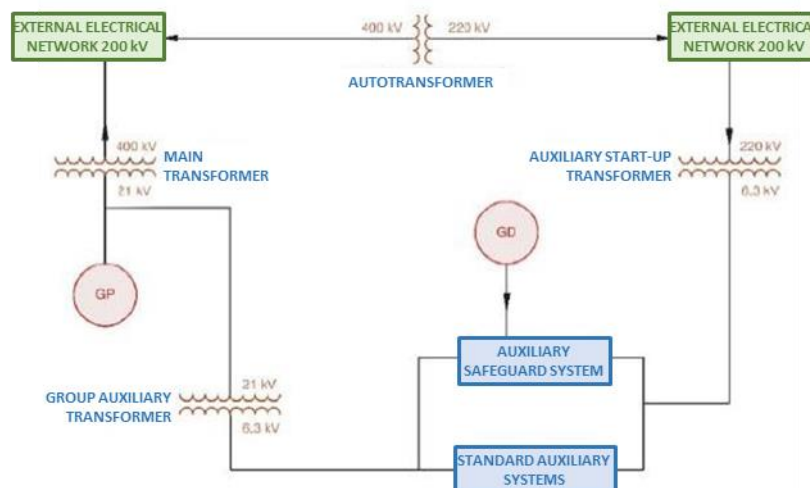

Figure 4: Block diagram of the external power supply in a nuclear power plant

As a result of the incident, the reactors that were operating at full power—Almaraz II, Ascó I and II, and Vandellós II—underwent automatic shutdowns due to the drop in grid frequency. The main actions taken at each of the NPPs units are summarised below:

- **Almaraz I NPP:** the plant had been in cold shutdown with the reactor in a subcritical state since 16 April, with core cooling maintained by the residual heat removal system. The voltage loss triggered the automatic start-up and engagement of the emergency diesel generators to restore voltage to the safety busbars, with the reconnection of loads to the safety busbars taking place without incident.
- **Almaraz II NPP:** In the seconds prior to the disconnection, several sudden drops in grid frequency were detected (12:32:57, 12:33:16 and 12:33:18), each of increasing amplitude. Following this last oscillation, 103.6% of the generator's rated voltage and a reactive power of -500 MVar were reached, causing the voltage regulator's minimum excitation limiter to trip. As the grid frequency decreased, the generator terminal voltage continued to rise (to a value of 108.6%). Finally, minimum frequency was reached at the normal busbars, causing the reactor cooling pumps to shut down and the reactor to shut down automatically.  
  
As in Unit I, the emergency diesel generators were started and connected to the safety busbars, followed by the reconnection of the necessary loads.
- **Ascó I and II NPPs:** in both units, the reactor automatically shut down due to a minimum frequency signal on the busbars supplying the reactor cooling pumps. The diesel generators started up due to minimum voltage on the safety busbars, subsequently coupling correctly to their busbars and correctly performing the load reconnection sequence.
- **Cofrentes NPP:** the plant was in a cold shutdown state, with the reactor in a subcritical condition. The two recirculation pumps and the residual heat removal system pump (RHR-B), which was in operation, tripped. Following a low-voltage signal on the emergency busbars of divisions I, II and III, the respective emergency diesel generators started up and connected to their respective busbars. The loads were connected sequentially as per design.
- **Trillo NPP:** the plant was shut down for refuelling. As a result of the loss of voltage in the external busbars, the safety busbars lost voltage, triggering the start-up and connection signals for the four safety diesel generators (GY10/20/30/40). The GY10/20/30 diesel generators started up and connected to their busbars correctly. The GY40 did not start, resulting in a zero voltage on its associated emergency busbar, which triggered the start-up of the GY80 emergency diesel generator; this generator connected correctly, restoring voltage to the emergency busbar. However, in the operating mode in which the plant was, the plant's technical operating specifications (ETF) only require two backup diesel generators to be operational; therefore, the failure of the GY40 to start had no safety implications.
- **Vandellós II NPP:** the reactor was automatically shut down due to a minimum frequency signal in the reactor cooling pumps. The emergency diesel generators and the essential diesel generator started up, supplying power to the safety busbars and critical switchgear.

The complete loss of external power at Spanish NPPs triggers the declaration of a "pre-emergency alert" in accordance with their on-site emergency plans (PEI). The plant operators carried out the actions associated with the pre-emergency alert, notifying the CSN of this status in accordance with their operating procedures.

Once the "power blackout" had been confirmed at all plants, REE proceeded gradually to restore the system by starting up systems capable of operating autonomously without external power supply (hydroelectric plants) to create energy islands. The process involves gradually adding generation (combined cycle gas turbines) and demand to these islands, which, once stabilised, must be interconnected until the system is fully restored. All these operations were coordinated by REE in accordance with its Service Restoration Procedures (PRS).

Spanish regional electricity distribution companies have internal procedures and coordination arrangements with REE to restore power supply from the grid to the facility. Following instructions from REE, service was gradually restored by creating isolated power islands from hydroelectric power plants, all subject to the condition of the national grid. The restoration of external electricity supply to the power plants took between 5 and 15 hours, depending on the characteristics and specific circumstances of each site and the stability of the electricity grid.

### **3. ACTIONS BY SPANISH THE NUCLEAR SAFETY COUNCIL**

#### **3.1 Activation of the emergency response organisation**

The CSN's Emergency Response Organisation (ORE) can operate in four response modes (0 to 3) depending on the severity, complexity or duration of the emergency. On 28 April, the emergency control room (SALEM) was activated in Mode 1 at 12:35, after the extent of the incident became known. The activation remained in place until 03:20 on 29 April, when it reverted to Level 0, or permanent alert, once the pre-alert had been downgraded by the last facility, Cofrentes nuclear power plant.

The main challenge facing the ORE was to maintain the operational continuity of communications, given that:

- Communications with the nuclear power plants experienced some intermittent interruptions. However, although continuous monitoring required operational adjustments at times, all facilities complied with the communications requirements set out in their on-site emergency plans and there was no need to activate alternative backup communication systems.
- At certain times, specific adjustments were made to communications with some operational coordination centres (CECOPs), without this hindering the overall performance of the functions associated with the management of off-site nuclear emergency plans.

In conclusion, the need to strengthen and diversify communication channels has been identified, as the importance of having additional alternative and redundant systems to ensure operational coordination, even in the most complex and adverse scenarios, has become apparent. Some of these systems are currently available, whilst others are at various stages of development.

As regards the ORE's operational response during the incident, the effectiveness and coordination of its actions were highlighted, particularly in the following aspects:

- There was close collaboration and effective coordination between the ORE's operational groups, which enabled the smooth running of their activities.
- The operational groups had the necessary personnel to carry out their activities, both during working hours when the activation began and outside of them. Coverage of work shifts was guaranteed despite the occasional difficulties encountered with communications and travel.
- The CSN's power generation system performed satisfactorily throughout the entire period it was required.
- The CSN's IT systems operated without any significant disruptions that would have prevented tasks from being carried out.
- Logistical and security requirements were amply met by dedicated staff from the Logistics Support Group.

### **3.2 Supervision by the CSN of the performance and operation of electrical systems at nuclear power plants during the pre-alert**

Following the incident on 28 April 2025, the CSN requested the following information from the operators of the nuclear power plants regarding the magnitude of the transient and the subsequent actions taken as a result:

1. Evolution of electrical variables in the external busbars, as well as the impact on electrical variables in the emergency busbars.
2. Sequence of activation and actions of electrical protection systems and margins recorded in relation to the set points of the most representative parameters (minimum voltage and/or overvoltage, minimum frequency, loss of synchronism, power oscillations, etc.).
3. Recent modifications (if any, subsequent to July 2021) to protection settings, indicating changes to both *settings* and time delays.
4. Actions taken and procedures followed by control room staff to restore the external power supply.
5. Actions taken and procedures followed regarding the diesel generators during the loss of external power supply and after service was restored.
6. Procedures carried out, in coordination with REE, to restore service.
7. Incidents that occurred during the restoration of service at power plants in the vicinity of the plant.

To address the aforementioned issues, the licence holders requested additional information from REE regarding the electrical variables of the substations (switch positions, active/reactive power, voltage and frequency), service restoration procedures, values of the 400 kV network protection systems that were triggered, as well as other notable events during the incident.

The CSN's Technical Directorate for Nuclear Safety (DSN) analysed the reports submitted by the power plants in response to the request for information, to assess whether the performance of the equipment and the operation of the Spanish nuclear power plants occurred in accordance with the design and applicable procedures from the perspective of the main electrical systems involved in the event.

The conclusions drawn from this assessment were as follows:

1. The internal electrical systems of the Spanish nuclear power plants performed correctly and kept the plants within their design parameters, so that nuclear safety was not compromised at any time. The only exception was the failure to start a safeguards diesel generator at Trillo Nuclear Power Plant, which posed no risk to emergency management as it was not required, given that the plant was in shutdown mode for refuelling. The emergency diesel generator in that redundancy system started correctly, supplying the associated emergency busbar. The power supply to essential safety loads was guaranteed at all times.
2. The electrical protection systems operated correctly as designed, and the licence holders have not reported any malfunctions in this regard. The modifications to the protection systems implemented since 2021 had no impact on the sequence of disconnections or the subsequent reconnection during restoration. Many of the alarms and protection systems did not activate as the time delays were not met, due to the speed at which the grid voltage and frequency degraded.

3. The automatic response of the plants' regulation and control systems was acceptable and in line with design specifications. The alarms generated were as expected for this event.
4. The joint response from the various control rooms, in coordination with REE, was adequate. The restoration of voltage from the hydroelectric power plants was rapid but not without difficulties, and on numerous occasions the restoration manoeuvres had to be repeated. This was due to the difference in the boundary conditions under which the current restoration procedures have been defined, which envisage a localised recovery of the electricity supply in a scenario far removed from the complete 'power blackout' that occurred during this event. External power supply to the normal busbars was restored swiftly within a matter of a few hours.

### **3.3 Supervision of the licensees' actions by the CSN resident inspectors**

As previously noted, the nationwide blackout that occurred in the Spanish electricity grid on 28 April 2025 at 12:33:24 triggered a pre-emergency alert due to a complete loss of external power supply (LPS) at the seven nuclear power plants in operation across Spain's five sites. Between 28 and 29 April, the emergency status was deactivated at all plants, following the restoration of power supplies from external lines and with no significant operational incidents recorded at any plant.

The CSN has a team of resident inspectors (RI) stationed at the nuclear power plants; the team at each plant consists of one resident inspector and one assistant resident inspector (ARI) in the case of a single unit, and one resident inspector and two assistant resident inspectors in the case of two units. At the time of the incident, resident inspection staff were present at each of the power plants and remained there until the pre-alert status was de-escalated.

In order to compile relevant information regarding the transient and the actions taken by the licence holders whilst the emergency pre-alert was in place at all nuclear power plants, the DSN requested the Deputy-Directorate for Nuclear Facilities to prepare a comprehensive report for all power plants, including information on the following aspects:

- Operational status of the unit prior to the LPS
- Sequence of events during the emergency
  - o Automatic response actions
  - o Manual response actions
  - o Actions to restore and normalise power supplies
  - o Administrative communications issued by the operator (essentially, those covered by the Emergency Plan)
- Incidents affecting communication systems
- Organisation of the operator during the emergency
- Significant failures in safety systems and operational incidents occurring during the emergency
- Actions taken by the CSN's resident inspector.

This summary analysis took into account the information gathered directly by the inspectors during the pre-alert, as well as other information and data provided by the licence holders or included in the pre-alert report which, in compliance with the on-site emergency plan and CSN Instruction IS-44, the licence holders are required to submit to the CSN.

The annex to this report includes, by way of summary, tables detailing the actions taken at each of the plants:

From the individual analysis of each of the seven units, as well as the comparative analysis of the information compiled by the plant's RI, a number of general conclusions have been drawn, which are set out below:

- At the moment the grid blackout occurred, the safety systems and equipment required to manage the emergency were operational at all seven units, and at none of them were carrying out significant activities that interfered with the management of the emergency.
- The automatic response actions of the safety systems following the occurrence of the LPS were as intended in the design at all units, with the sole exception of the failure during start-up of the GY40 backup diesel generator at Trillo NPP; in response to this failure, the emergency diesel generator GY80 started up and synchronised automatically, in accordance with the design and, therefore, with no impact on safety.
- The manual response actions carried out by the operating shifts in response to the LPS condition were correct and in accordance with the provisions of the applicable procedures at the five plants.
- At all seven units, the procedures for restoring external power supply applicable in the event of a power failure were successfully implemented, although recovery times varied depending on the characteristics and specific features of each site and the stability of the electricity grid; this led to the loss of some lines once power had been restored and, in other cases, to the extension of the pre-emergency alert status.
- At the five nuclear power plants, isolated incidents were recorded in the communication systems associated with the loss of power supply, which required the adoption of management measures, both internally and in relations with the various external stakeholders. The scope and duration of these incidents varied greatly depending on the site, although in all cases compliance with the communication requirements established in the Emergency Response Plans (ERPs) was maintained.
- During the pre-alert, there were some isolated failures in safety components (failure on start-up of GY40 at Trillo NPP and on opening of the relief valve of steam generator A at Vandellós II NPP) and some operational incidents. In no case did this cause problems for emergency management or have an impact on safe operation. The causes of each failure or incident are known and, where deemed applicable, the licence holders have taken the corresponding corrective measures.
- At all five plants, a pre-emergency alert was declared in accordance with trigger 1.2.1 of the Emergency Plan (EP), and the emergency was deactivated after carrying out the checks set out in the procedures, once the operating conditions of the units were deemed stable and safe, and the external power supply was considered to have been restored and secured. The duration of the emergency depended, in each case, on the time at which the external power supply was restored and the time required to complete the recovery actions, ranging from 5 to 15 hours. During the emergency, the licence holders issued the relevant communications, although some incidents affecting the communication systems had a limited impact on the pace at which these were sent. No deficiencies were detected regarding the communications required by the Emergency Response Plans (ERPs).
- Throughout the emergency, the licence holders' organisation responded appropriately, with no instances of unfilled posts or organisational problems that impacted the emergency response or the safety of the facilities. Incidents in the communication systems made it necessary, in some

cases, to implement supplementary procedures regarding communications and staff organisation; however, in all cases the situations were resolved satisfactorily. At all times, operational shifts and on-call posts were covered. Technical Support Centres (CATs) were established and maintained in operation without problems; at some plants, the CAT was located at the Alternative Emergency Management Centre (CAGE). There were no problems with shift changes. In some cases, it was necessary to use the CAGE for staff rest and refreshments.

- On 28 April 2025, the availability of CSN resident inspectors at each site varied from one facility to another. At Cofrentes and Trillo, only the resident inspectors were available, as the assistant resident inspectors were on leave. At Almaraz, the resident inspector and the assistant resident inspector were available, as the other assistant resident inspector was on leave. At Ascó and Vandellós-II, all inspectors were available (three at Ascó and two at Vandellós-II), and arrangements were made for a resident inspector to travel to the Government Sub-delegation in Tarragona and take up the post of head of the radiological group from the start of the emergency. At the plants where more than one inspector was available, appropriate decisions were taken to organise possible relief shifts. In the case of Cofrentes, given the protracted nature of the emergency, the CSN sent a technical expert from Madrid to act as a substitute resident inspector on 29 April 2025.
- Although the resident inspection team did not have access to the full sets of equipment in most cases, and despite occasional communication issues (both internally, at the power plants, and externally with the CSN and CECOP), it was able to monitor developments in the operational situation at each unit and report to the CSN and CECOP in a timely manner.

#### 4. CONCLUSIONS

The main conclusions drawn from the assessment carried out are as follows:

- The electrical protection systems at the nuclear power plants functioned as designed.
- The automatic response actions of the power plants' safety systems following the LPS (reactor trip, diesel generator start-up, load transfer sequence) were in accordance with design. The only exception (and bearing in mind that this was not required by the ETF) was the failure of the GY40 diesel generator at Trillo NPP to start; instead, the GY80 started and coupled to the emergency busbar, as designed.
- The manual response actions taken by the operators in response to the LPS were correct, in accordance with the applicable procedures.
- The licence holders, in communication with REE, successfully applied the procedures for restoring power supply from the external grid, although recovery times varied depending on the configuration at each site and the stability of the grid at each location. At three of the plants, some previously restored lines were lost due to grid instability for several hours, until the external power supply finally stabilised.
- At all five nuclear power plants, isolated incidents were recorded in the communication systems associated with the loss of power supply, which required the adoption of management measures, both internally and in relations with the various external stakeholders. The scope and duration of these incidents varied greatly across the sites, although in all cases compliance with the communication requirements established in the PEIs was maintained.
- All plants carried out the emergency actions set out in the PEIs, corresponding to the LPS situation (initiating event 1.2.1), in an appropriate manner. The pre-alerts were deactivated after verifying

that operating conditions were stable and safe, and that the external power supply had been restored.

- The licence holders' organisation responded appropriately during the emergency. All required operational shifts and on-site teams were covered. The CATs remained operational and the necessary relief shifts took place. However, at times it was necessary to adjust certain communication and staff organisation procedures as a result of incidents affecting the available systems.
- The availability of resident inspectors was ensured at all sites. Where possible, the necessary relief shifts were organised.
- Despite the communication incidents, the RI was able to monitor the development of the operational situation at each plant, reporting to the CSN headquarters and the CECOPs (or Civil Protection, or Government Sub-delegation, depending on the situation in each province).
- The CSN's ORE was activated immediately following the incident and remained operational until the last facility lifted the pre-alert.
- The CSN's SALEM support systems, including electrical, IT and logistical systems, operated stably and reliably, enabling the operational teams to carry out their duties with continuity and coordination.

**ANNEX: Summary tables of the actions taken by the power plants**

**Almaraz NPP:** duration of the emergency pre-alert 11.7 hours

	Unit I	Unit II
Operational status	MODE 5 (COLD SHUTDOWN)	MODE 1 (69% power)
Operational faults / incidents	After establishing supply from Valdecañas HPP during the initial phase of the emergency, it was lost at 13:55 (28/04/25). Supply was restored from Oriol HPP between 14:35 and 17:20 (28/04/25)	
Organisation of the licence holder	Satisfactory, although there have been issues with locating staff at the replacement checkpoints	
Action taken by the RI	<ul style="list-style-type: none"> <li>• RIs available at the control centre: 2 out of 3</li> <li>• Monitoring of the emergency from the control centre from start to finish</li> <li>• Contact with Civil Protection was made at the start of the emergency, coinciding with a situation of limited availability of the CECOP during the pre-alert.</li> <li>• RIs were in contact with CSN (SCN/INRE)</li> <li>• Telephone contact with SALEM was not restored until 21:35 (28/04/25)</li> <li>• The RI organised itself for a possible relief shift (not required)</li> </ul>	

Ascó NPP: duration of the emergency pre-alert 5.2 hours

	Unit I	Unit II
Operational status	MODE 1 (71% power)	MODE 1 (100% power)
Operational faults / incidents	Nothing significant	Opening of the pressuriser relief valve (however, it opened and closed as designed)
Licensee's organisation	<p>Adequate, with no personnel management issues</p> <p>The emergency was managed from the CAGE</p> <p>The ORE remained activated until the morning of 29 April 2025</p>	
Action taken by the RI	<ul style="list-style-type: none"> <li>• RIs available at headquarters: 3 out of 3</li> <li>• Monitoring of the emergency by the 3 RIs from the control centre from start to finish</li> <li>• Coordination with the RI of Vandellós-II NPP (RI of Vandellós-II NPP at CECOP from the start of the pre-alert)</li> <li>• Communication with Civil Protection from the start of the emergency</li> <li>• RIs were in contact with the CSN (Salem and SCN/INRE)</li> <li>• In coordination with the Vandellós-II RI, arrangements were made to carry out relief shifts</li> </ul>	

**Cofrentes NPP: duration of the emergency pre-alert 14.8 hours**

Operational status	OPERATING CONDITION 4 (COLD SHUTDOWN)
Operational faults/incidents	<ul style="list-style-type: none"> <li>Start-up of the RHR-B pump (residual heat removal system) with the circuit depressurised due to the feed pump being out of service; no consequences (under investigation)</li> <li>After establishing supply from the Cortes-La Muela power plant and the Cofrentes power plant in the initial phase of the emergency, the former was lost at 15:28. At 15:56, supply was established from the Collado substation. Supply from the Cortes-La Muela power plant was restored at 18:05 (28/04/25)</li> </ul>
Organisation of the operator	Adequate, although there were problems locating staff for the replacement teams
Action by the RI	<ul style="list-style-type: none"> <li>RIs available at the control centre: 1 out of 2</li> <li>Monitoring of the emergency by the RI from the control centre from start to finish</li> <li>Communication with CECOP between 14:00 and 15:00 (28/04/25). It was agreed as a precautionary measure that the RI would remain at the plant, given the uncertainty regarding travel conditions to Valencia.</li> <li>The RI was in intermittent contact with the CSN (SALEM and SCN/INRE) and with CECOP, depending on the availability of the various communication systems.</li> <li>The RI remained at the plant until 03:45 (29/04/25)</li> <li>On 29 April 2025, the SCN technical adviser acted as a stand-in RI at the plant</li> </ul>

Trillo NPP: duration of the emergency pre-alert 13.8 hours

Operational status	MODE 5 (REFUELLING)
Operational faults/incidents	<ul style="list-style-type: none"> <li>• Failure on start-up of the GY40 backup diesel generator (as per design, the GY80 emergency diesel generator started up and synchronised). The ETF in MODE 5 does not require this.</li> <li>• Losses of the 220 kV power supply restored from Bolarque substation at 14:03 (on 4 occasions), until full restoration at 20:28 (28/04/25)</li> </ul>
Organisation of the operator	<p>Adequate, although there were issues with staffing the replacement checkpoints</p> <p>The CAGE was used for staff rest</p>
Action taken by the RI	<ul style="list-style-type: none"> <li>• RIs available at the plant: 1 out of 2</li> <li>• Monitoring of the emergency by the RI from headquarters until 22:00 (28/04/25)</li> <li>• At 13:20 on 28 April 2025, communication was maintained with the Government Sub-delegation as part of the monitoring of the situation.</li> <li>• The RI was in intermittent contact with the CSN (SALEM and SCN/INRE) and the Government Sub-delegation, depending on the availability of the various communication systems.</li> <li>• At around 22:00 (28/04/25), the RI travelled to Guadalajara to contact the Government Sub-delegation</li> <li>• Consideration was given to sending a technical expert from headquarters to the plant on 29 April 2025 to act as a stand-in RI (not necessary)</li> </ul>

**Vandellós 2 NPP:** duration of the emergency pre-alert 4.8 hours

Operational status	OPERATING CONDITION 1 (100% power)
Operational faults/incidents	<ul style="list-style-type: none"> <li>• Failure on opening of the steam generator A relief valve (no consequences, as the other valves opened correctly)</li> </ul>
Licensee's organisation	Adequate, with no personnel management issues
Action by the RI	<ul style="list-style-type: none"> <li>• RIs available at the plant: 2 out of 2</li> <li>• At the beginning of the emergency, in coordination with the Ascó NPP RI, it was decided that the Vandellós-II NPP RI would travel to the CECOP and act as head of the radiological group</li> <li>• Monitoring of the emergency from the plant by the ARI from start to finish</li> <li>• The ARI remained in contact with the CSN (SALEM) and CECOP</li> <li>• The RI attended the plant following the deactivation of the CECOP (18:30, 28/04/25) to monitor recovery operations, where he remained until 21:30 (28/04/25), once mobile phone service had been restored</li> </ul>