

## **APPROVAL CERTIFICATE FOR A PACKAGE DESIGN**

The Competent French Authority,

Having regard to Article R. 595-1 of the French Environmental Code;

Having regard to the request submitted by the company Orano NPS in letter COR-22-000220-013 dated 22 February 2022;

Having regard to safety analysis report DOS-18-016471-000 Rev. 5.0 dated 21 February 2022 supplemented by note D02-ARV-01-186-614 revision B of 10 May 2022 ;

Having regard to the certificate previously issued under reference F/347/IF-96 (Fv);

Having regard to the results of the public consultation conducted from 29 June 2021 to 14 July 2021;

Hereby certifies that the package design comprising the **FCC3** packaging described hereafter in Appendix 0 revision x and loaded with:

- up to 2 new PWR 17 x 17 twelve-foot fuel assemblies, in version 1 of the packaging, as described in Appendix 1 revision x; or
- up to 2 new PWR 15 x 15 fuel assemblies, in version 1 of the packaging, as described in Appendix 2 revision x; or
- up to 2 new PWR 14 x 14 eight-foot fuel assemblies, in version 2 of the packaging, as described in Appendix 3 revision x; or
- up to 2 new PWR 14 x 14 ten-foot fuel assemblies, in version 2 of the packaging, as described in Appendix 4 revision x; or
- up to 2 boxes containing new, unassembled PWR 17 x 17 twelve-foot fuel rods, in version 1 of the packaging, as described in Appendix 5 revision x; or
- up to 2 boxes containing new, unassembled PWR 15 x 15 fuel rods, in version 1 of the packaging, as described in Appendix 6 revision x; or
- up to 2 boxes containing new, unassembled PWR 14 x 14 eight-foot fuel rods, in version 1 of the packaging, as described in Appendix 7 revision x; or
- up to 2 boxes containing new, unassembled PWR 14 x 14 ten-foot fuel rods, in version 1 of the packaging, as described in Appendix 8 revision x;

is compliant as **an IP-2-type package design loaded with fissile materials**, with the requirements of the regulations and agreements listed below:

- International Atomic Energy Agency (IAEA) Regulations for the Safe Transport of Radioactive Material, Safety Standards Series No. SSR-6 (Rev. 1), 2018 Edition;
- Agreement concerning the International Carriage of Dangerous Goods by Road (ADR);
- European Agreement concerning the International Carriage of Dangerous Goods by Inland Waterways (ADN);

- Regulation concerning the International Carriage of Dangerous Goods by Rail (RID);
- International Maritime Dangerous Goods Code (IMDG Code of the IMO);
- amended French order of 23 November 1987 on the safety of ships, and particularly section 411 of the appended regulation (the "RSN" order);
- amended French Order of 29 May 2009, on the carriage of dangerous goods by overland routes (the "TMD" order).

This certificate does not release the shipper from the obligation to comply with the requirements laid down by the authorities of the countries through or to which the package is to be shipped.

This certificate expires on 30 April 2028.

Registration number: **CODEP-DTS-2022-027482**.

Signed in Montrouge, 13 June 2022

On behalf of the President of the French Nuclear Safety  
Authority  
and, by delegation,  
the Director of Transport and Sources,

**Fabien FÉRON**



## ANNEXE 0 FCC3 PACKAGING

### 1. DESCRIPTION OF THE PACKAGING

The packaging was designed, manufactured, inspected, tested, maintained and used in compliance with safety analysis report DOS-18-016471-000 Rev. 5.0.

The packaging, which is generally cylindrical in shape, is shown in figures 0.1 and 0.2.

The packaging design drawings bear the reference numbers 229K0100, 229K0200 and 229K0700 for version 1 and 229K0300 for version 2.

The overall external dimensions of the packaging are:

length: 4,931 mm:

width: 1,145 mm:

height: 1,217 mm

The maximum permissible mass of the loaded packaging during transport is 4,385 kg.

The packaging comprises the following main sub-assemblies:

#### 1.1 Packaging body

The FCC3 packaging consists of a cylindrical enclosure, with a horizontal axis, composed of two linked half-shells comprising :

- a metal cradle consisting of two longitudinal members and suspended from the lower shell by means of rubber shock absorbers;
- an internal equipment resting on the cradle and intended to house one of the contents.

This internal equipment is composed of :

- a support frame with a rigid, inverted “T”-shaped structure designed to hold the content in place horizontally. The fabricated part of the frame contains neutron-absorbing resin. A tilting pin on the bottom plate allows the support frame to be moved into a vertical position for loading or unloading assemblies;
- two 'L' shaped doors containing neutron-absorbing resin which are attached to the support frame and encapsulate the contents;
- a bottom plate supporting the fuel assemblies during loading and unloading when the support frame is in the upright position;
- a two-piece top plate, which serves to close the cavities and secure the contents at the other end.

#### 1.2 Packaging closing system

The two cylindrical half-shells are connected together using 30 bolts.

The doors and top plates are connected to the frame using ball pins and spindles.

The bottom plate is screwed to the frame.

#### 1.3 Shock-absorbing systems

Two axial shock absorbers are attached to the end of the upper shell. They are composed of two metal boxes containing a block of balsa wood.

Two additional axial shock absorbers are attached to the top plates when transporting assemblies with rod clusters.

#### **1.4 Handling and tie-down elements**

Items are handled using a suitable lifting beam or slings equipped with shackles or hooks, according to one of the following two lifting methods:

- By 4 lifting boxes welded to the upper shell and made of a folded sheet of metal with a hole in it for a shackle or a hook;
- By fork slots located under the lower shell.

The packaging is also designed so that it can be secured during transportation in accordance with the recommendations in chapter 1.7 of safety analysis report DOS-18-016471-014 Rev. 2.0.

#### **1.5 Safety functions**

**Containment and radiation protection** functions are provided by the fuel rods.

**Sub-criticality continuity** is guaranteed by the isolation system consisting of the elements identified in the appendices describing the contents and, for the packaging, by the following elements:

- the internal equipment, consisting of the frame, doors and end plates and, in the case of rod boxes, the radial and axial spacer system and the rod boxes themselves, together forming two neutron cavities;
- neutron-absorbing resin contained in the doors and frame;
- the upper and lower shells that protect the internal equipment in normal and accident conditions of transport.

**The fuel is protected against impacts** by the two half-shells and the internal equipment.

**Fire protection** is mainly provided by the two half-shells, the internal equipment and the resin in the doors and frame.

## **2. ACTIONS TO BE TAKEN BY THE SHIPPER PRIOR TO SHIPPING THE PACKAGE**

The packaging is to be used in accordance with procedures that comply with the instructions for use in Chapter 1.7 of safety analysis report DOS-18-016471-014 Rev. 2.0.

The transport of ERU fuel is only permitted under exclusive use.

## **3. MAINTENANCE PROGRAMME**

The packaging is to be maintained in accordance with the procedures described in Chapter 1.8 of safety analysis report DOS-18-016471-015 Rev. 1.0.

Any packaging that does not meet the criteria specified in the maintenance programme must be taken out of service until the appropriate corrective action has been taken.

## **4. NOTIFICATION**

The ASN shall be kept informed via the following email address: [dts-transport@asn.fr](mailto:dts-transport@asn.fr) of any packaging that is taken out of service or transferred to another owner. Accordingly, any owner that transfers a packaging must communicate the name of the new owner.

## **5. QUALITY MANAGEMENT SYSTEM**

The principles of the quality management system to be applied to the design, manufacture, inspection, testing, maintenance and use of the package must comply with the principles described in Chapter 1.9 of safety analysis report DOS-18-016471-013 Rev. 1.0.

**FIGURE 0.1**  
**PACKAGING DIAGRAM**

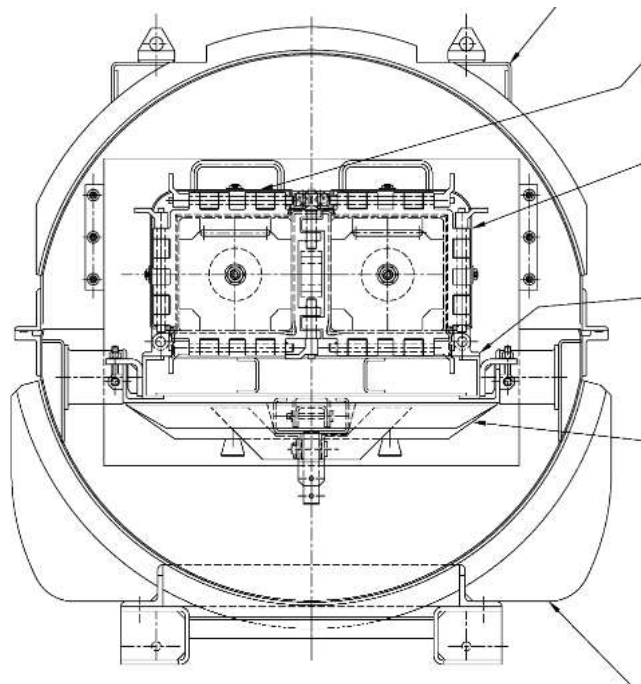
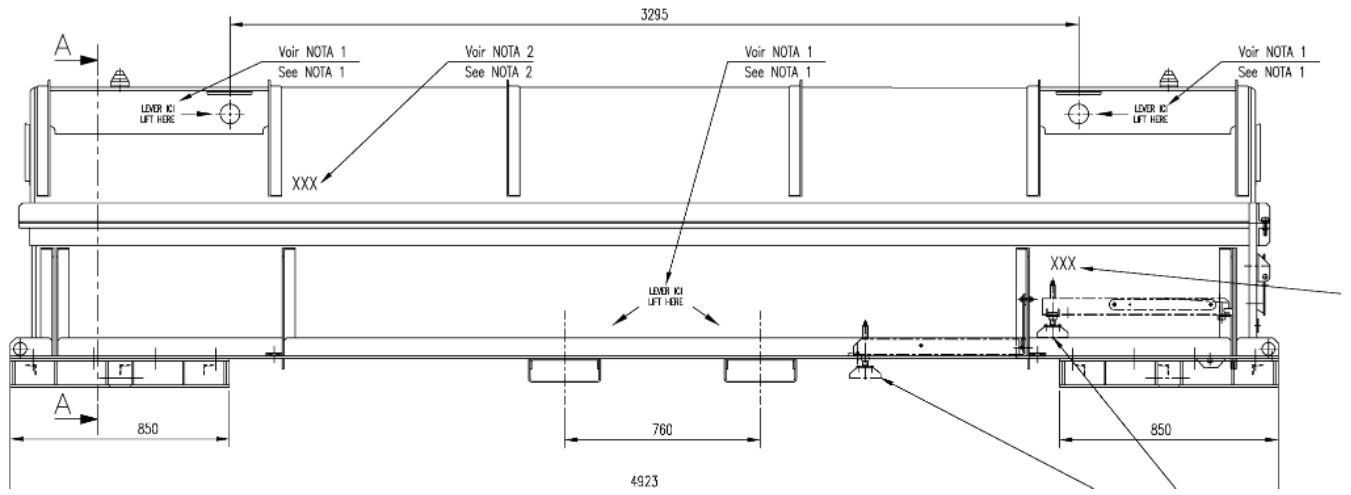
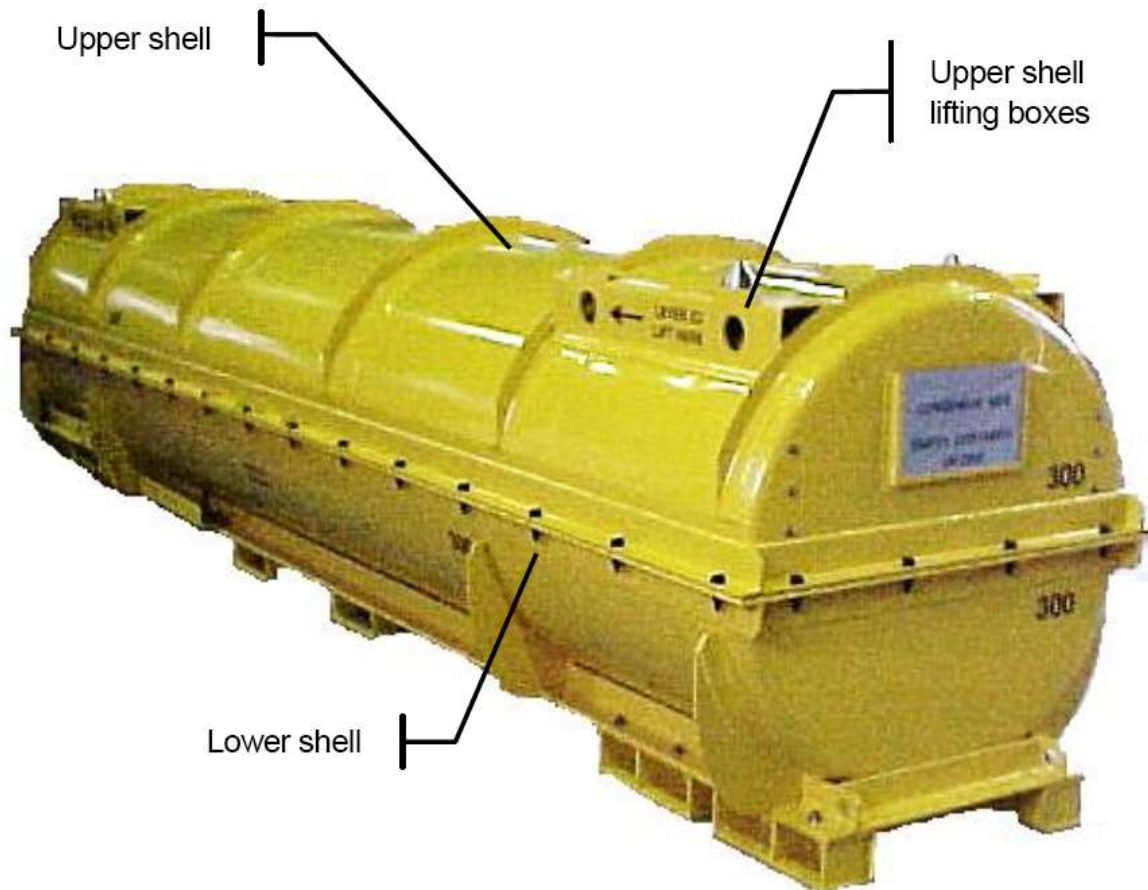

FIGURE 0.2  
THREE-DIMENSIONAL VIEW OF THE PACKAGING



**ANNEXE 1**  
**CONTENT NO. 1**  
**NEW PWR TYPE 17 X 17 TWELVE-FOOT FUEL ASSEMBLIES**

The safety analysis report justifying the authorised content is report DOS-18-016471-000 Rev. 5.0.  
This content is loaded into a version 1 FCC3 packaging.

**1. DEFINITION OF AUTHORISED RADIOACTIVE CONTENT**

The authorised radioactive content, which are described in Chapter 1.3 of safety analysis report DOS-18-016471-006 Rev. 4.0, consist of a maximum of two new fuel assemblies for pressurized water reactor (PWR), as described below:

<b>Characteristics of the fuel assemblies</b>	
Type of array	17 x 17 twelve foot
Nominal array pitch (mm)	12.6
Total maximum mass of a fuel assembly with or without a rod cluster (kg)	757
Maximum mass of UO <sub>2</sub> per assembly (kg)	591
Nominal active length (mm)	3,658
Maximum number of fuel rods	288 <sup>(1)</sup>
<b>Characteristics of fuel rods</b>	
Cladding material	Zirconium alloy, possibly pre-oxidised, possibly chromium-plated
Minimum metal thickness (mm)	0.52
Minimum outer diameter (mm)	9.40
Pellets:	ERU <sup>(2)</sup>   ENU <sup>(2)</sup>
Maximum diameter (mm)	8.30
Maximum oxide density (100% of the theoretical density)	10.96
Maximum initial enrichment ( <sup>235</sup> U/U <sub>total</sub> ) (%)	5
Maximum mass ratio <sup>232</sup> U/U <sub>total</sub> (%)	5x10 <sup>-6</sup>   5x10 <sup>-8</sup>
Maximum mass ratio <sup>234</sup> U/U <sub>total</sub> (%)	0.30   0.055
Maximum mass ratio <sup>236</sup> U/U <sub>total</sub> (%)	4   0.05
Maximum absolute internal pressure of fuel rods at 20 °C (in bar)	32.7
(1) This number corresponds to the maximum number of fuel rods that can be inserted into a structure (assembly skeleton or quiver), including guide tubes.	
(2) ERU/ENU: Enriched Reprocessed Uranium / Enriched Natural Uranium.	

Glycerine residues up to a maximum of 5 grams can be present on the fuel assemblies.

The mechanical strength properties of the fuel rod cladding material meet one of the following two triplets:

	1	2
<b>R<sub>p0.2</sub> (MPa)</b>	≥ 520	≥ 250
<b>R<sub>m</sub> (MPa)</b>	≥ 710	≥ 400
<b>A<sub>t</sub> (% over 50 mm)</b>	≥ 12	≥ 25

Maximum activity per packaging: 0.887 TBq in case of ERU.

Material classification: LSA II for ENU fuel rods.  
LSA III for ERU fuel rods.

Physical state: Fuel rod assemblies composed of sintered pellets in a Zirconium alloy cladding, which may be pre-oxidised. The cladding can be covered with a layer of chromium up to 30 µm thick.

Chemical form: Uranium oxide (UO<sub>2</sub>) pellets and/or fuel pellets composed of a mixture of UO<sub>2</sub> and a body that acts as a neutron poison. The pellets may contain chromium oxide (but no other doping agents).

Special form: The material transported is not in any special form.

## 2. LOADING CONDITIONS

All assemblies in a load meet the conditions defined in the following table:

Maximum initial enrichment per fuel rod for each assembly in the load ( <sup>235</sup> U/U <sub>total</sub> )	Minimum number of fuel rods per fuel assembly in the load <sup>(1)</sup>
5 %	264
(1) Incomplete UO <sub>2</sub> fuel rod assemblies can be supplemented with gadolinium-carrying rods, rods containing depleted uranium or other metallic material, or bars filled with a metallic material (excluding graphite and beryllium), possibly containing a neutron poison. These supplementary rods or bars will be equivalent in size to the UO <sub>2</sub> rods. The expression "number of rods per assembly" is understood to mean the total number of fuel rods and replacement rods or bars.	

All fuel assemblies in the load, except one, can be replaced by fuel assembly skeletons.

The presence of desiccant is permitted.

The presence of materials with more hydrogen content than water is not authorised within the packaging.

## 3. SUB-CRITICALITY CONTINUITY

Sub-criticality continuity is covered in Chapter 2.5-1 of the safety analysis report.

The "content" part of the isolation system under consideration comprises the following elements:

- the characteristics of the fuel assemblies as described in the Table in Chapter 1 of this Appendix;
- the cladding tubes which guarantee the containment of the fissile material in an accident situation;
- the structure of the assembly (grids, end-pieces).

Criticality Safety Index (CSI): 0.625 ("N" number = 80).

**ANNEXE 2**  
**CONTENT NO. 2**  
**NEW PWR TYPE 15 X 15 FUEL ASSEMBLIES**

The safety analysis report justifying the authorised content is report DOS-18-016471-000 Rev. 5.0.  
This content is loaded into a version 1 FCC3 packaging.

**1. DEFINITION OF AUTHORISED RADIOACTIVE CONTENT**

The authorised radioactive content, which are described in Chapter 1.3 of safety analysis report DOS-18-016471-006 Rev. 4.0, consist of a maximum of two new fuel assemblies for pressurized water reactor (PWR), as described below:

<b>Characteristics of the fuel assemblies</b>	
Type of array	15 x 15
Nominal array pitch (mm)	14.3
Total maximum mass of a fuel assembly with or without a rod cluster (kg)	749
Maximum mass of UO <sub>2</sub> per assembly (kg)	589
Nominal active length (mm)	3,658
Maximum number of fuel rods	224 <sup>(1)</sup>
<b>Characteristics of fuel rods</b>	
Cladding material	Zirconium alloy, possibly pre-oxidised, possibly chromium-plated
Minimum metal thickness (mm)	0.57
Minimum outer diameter (mm)	10.68
Pellets:	ERU <sup>(2)</sup>   ENU <sup>(2)</sup>
Maximum diameter (mm)	9.40
Maximum oxide density (100% of the theoretical density)	10.96
Maximum initial enrichment ( <sup>235</sup> U/U <sub>total</sub> ) (%)	5
Maximum mass ratio <sup>232</sup> U/U <sub>total</sub> (%)	5x10 <sup>-6</sup>   5x10 <sup>-8</sup>
Maximum mass ratio <sup>234</sup> U/U <sub>total</sub> (%)	0.30   0.055
Maximum mass ratio <sup>236</sup> U/U <sub>total</sub> (%)	4   0.05
Maximum absolute internal pressure of fuel rods at 20 °C (in bar)	32.7
(1) This number corresponds to the maximum number of fuel rods that can be inserted into a structure (assembly skeleton or quiver), including guide tubes.	
(2) ERU/ENU: Enriched Reprocessed Uranium / Enriched Natural Uranium.	

Glycerine residues up to a maximum of 5 grams can be present on the fuel assemblies.

The mechanical strength properties of the fuel rod cladding material meet one of the following two triplets:

	1	2
<b>R<sub>p0.2</sub> (MPa)</b>	≥ 520	≥ 250
<b>R<sub>m</sub> (MPa)</b>	≥ 710	≥ 400
<b>A<sub>t</sub> (% over 50 mm)</b>	≥ 12	≥ 25

Maximum activity per packaging: 0.883 TBq in case of ERU.

Material classification: LSA II for ENU fuel rods.  
LSA III for ERU fuel rods.

Physical state: Fuel rod assemblies composed of sintered pellets in a Zirconium alloy cladding, which may be pre-oxidised. The cladding can be covered with a layer of chromium up to 30 µm thick.

Chemical form: Uranium oxide (UO<sub>2</sub>) pellets and/or fuel pellets composed of a mixture of UO<sub>2</sub> and a body that acts as a neutron poison. The pellets may contain chromium oxide (but no other doping agents).

Special form: The material transported is not in any special form.

## 2. LOADING CONDITIONS

All assemblies in a load meet the conditions defined in the following table:

Maximum initial enrichment per fuel rod for each assembly in the load ( <sup>235</sup> U/U <sub>total</sub> )	Minimum number of fuel rods per fuel assembly in the load <sup>(1)</sup>
5 %	204
(1) Incomplete UO <sub>2</sub> fuel rod assemblies can be supplemented with gadolinium-carrying rods, rods containing depleted uranium or other metallic material, or bars filled with a metallic material (excluding graphite and beryllium), possibly containing a neutron poison. These supplementary rods or bars will be equivalent in size to the UO <sub>2</sub> rods. The expression “ <i>number of rods per assembly</i> ” is understood to mean the total number of fuel rods and replacement rods or bars.	

All fuel assemblies in the load, except one, can be replaced by fuel assembly skeletons.

The presence of desiccant is permitted.

The presence of materials with more hydrogen content than water is not authorised within the packaging.

## 3. SUB-CRITICALITY CONTINUITY

Sub-criticality continuity is covered in Chapter 2.5-1 of the safety analysis report.

The “content” part of the isolation system under consideration comprises the following elements:

- the characteristics of the fuel assemblies as described in the Table in Chapter 1 of this Appendix;
- the cladding tubes which guarantee the containment of the fissile material in an accident situation;
- the structure of the assembly (grids, end-pieces).

Criticality Safety Index (CSI): 0.625 (“N” number = 80).

**ANNEXE 3**  
**CONTENT NO. 3**  
**NEW PWR TYPE 14 X 14 EIGHT-FOOT FUEL ASSEMBLIES**

The safety analysis report justifying the authorised content is report DOS-18-016471-000 Rev. 5.0.  
This content is loaded into a version 2 FCC3 packaging.

**1. DEFINITION OF AUTHORISED RADIOACTIVE CONTENT**

The authorised radioactive content, which are described in Chapter 1.3 of safety analysis report DOS-18-016471-006 Rev. 4.0, consist of a maximum of two new fuel assemblies for pressurized water reactor (PWR), as described below:

<b>Characteristics of the fuel assemblies</b>	
Type of array	14 x 14 eight foot
Nominal array pitch (mm)	14.1
Total maximum mass of a fuel assembly with or without a rod cluster (kg)	448
Maximum mass of UO <sub>2</sub> per assembly (kg)	346
Nominal active length (mm)	2,413
Maximum number of fuel rods	195 <sup>(1)</sup>
<b>Characteristics of fuel rods</b>	
Cladding material	Zirconium alloy, possibly pre-oxidised, possibly chromium-plated
Minimum metal thickness (mm)	0.57
Minimum outer diameter (mm)	10.68
Pellets:	ERU <sup>(2)</sup>   ENU <sup>(2)</sup>
Maximum diameter (mm)	9.40
Maximum oxide density (100% of the theoretical density)	10.96
Maximum initial enrichment ( <sup>235</sup> U/U <sub>total</sub> ) (%)	5
Maximum mass ratio <sup>232</sup> U/U <sub>total</sub> (%)	5x10 <sup>-6</sup>   5x10 <sup>-8</sup>
Maximum mass ratio <sup>234</sup> U/U <sub>total</sub> (%)	0.30   0.055
Maximum mass ratio <sup>236</sup> U/U <sub>total</sub> (%)	4   0.05
Maximum absolute internal pressure of fuel rods at 20 °C (in bar)	32.7
(1) This number of rods corresponds to the maximum number of rods that can be inserted into a structure (assembly skeleton or quiver), including in the guide tubes.	
(2) ERU/ENU: Enriched Reprocessed Uranium / Enriched Natural Uranium.	

Glycerine residues up to a maximum of 5 grams can be present on the fuel assemblies.

The mechanical strength properties of the fuel rod cladding material meet one of the following two triplets:

	1	2
<b>R<sub>p0.2</sub> (MPa)</b>	≥ 520	≥ 250
<b>R<sub>m</sub> (MPa)</b>	≥ 710	≥ 400
<b>A<sub>t</sub> (% over 50 mm)</b>	≥ 12	≥ 25

Maximum activity per packaging: 0.519 TBq in case of ERU.

Material classification: LSA II for ENU fuel rods.  
LSA III for ERU fuel rods.

Physical state: Fuel rod assemblies composed of sintered pellets in a Zirconium alloy cladding, which may be pre-oxidised. The cladding can be covered with a layer of chromium up to 30 µm thick.

Chemical form: Uranium oxide (UO<sub>2</sub>) pellets and/or fuel pellets composed of a mixture of UO<sub>2</sub> and a body that acts as a neutron poison. The pellets may contain chromium oxide (but no other doping agents).

Special form: The material transported is not in any special form.

## 2. LOADING CONDITIONS

All assemblies in a load meet the conditions defined in the following table:

Maximum initial enrichment per fuel rod for each assembly in the load ( <sup>235</sup> U/U <sub>total</sub> )	Minimum number of fuel rods per fuel assembly in the load <sup>(1)</sup>
5 %	179
(1) Incomplete UO <sub>2</sub> fuel rod assemblies can be supplemented with gadolinium-carrying rods, rods containing depleted uranium or other metallic material, or bars filled with a metallic material (excluding graphite and beryllium), possibly containing a neutron poison. These supplementary rods or bars will be equivalent in size to the UO <sub>2</sub> rods. The expression "number of rods per assembly" is understood to mean the total number of fuel rods and replacement rods or bars.	

All fuel assemblies in the load, except one, can be replaced by fuel assembly skeletons.

The presence of desiccant is permitted.

The presence of materials with more hydrogen content than water is not authorised within the packaging.

## 3. SUB-CRITICALITY CONTINUITY

Sub-criticality continuity is covered in Chapter 2.5-3 of the safety analysis report.

The isolation system under consideration comprises the following elements:

- the characteristics of the fuel assemblies as described in the Table in Chapter 1 of this Appendix;
- the cladding tubes which guarantee the containment of the fissile material in an accident situation;
- the structure of the assembly (grids, end-pieces).

Criticality Safety Index (CSI): 0 (Number N = infinity).

**ANNEXE 4  
CONTENT NO. 4**

**NEW PWR TYPE 14 X 14 TEN-FOOT FUEL ASSEMBLIES**

The safety analysis report justifying the authorised content is report DOS-18-016471-000 Rev. 5.0.  
This content is loaded into a version 2 FCC3 packaging.

**1. DEFINITION OF AUTHORISED RADIOACTIVE CONTENT**

The authorised radioactive contents, which are described in Chapter 1.3 of safety analysis report DOS-18-016471-006 Rev. 4.0, consist of a maximum of two new fuel assemblies for pressurized water reactor (PWR), as described below:

<b>Characteristics of the fuel assemblies</b>	
Type of array	14 x 14 ten foot
Nominal array pitch (mm)	14.1
Total maximum mass of a fuel assembly with or without a rod cluster (kg)	557
Maximum mass of UO <sub>2</sub> per assembly (kg)	437
Nominal active length (mm)	3,048
Maximum number of fuel rods	195 <sup>(1)</sup>
<b>Characteristics of fuel rods</b>	
Cladding material	Zirconium alloy, possibly pre-oxidised, possibly chromium-plated
Minimum metal thickness (mm)	0.57
Minimum outer diameter (mm)	10.68
Pellets:	ERU <sup>(2)</sup>   ENU <sup>(2)</sup>
Maximum diameter (mm)	9.40
Maximum oxide density (100% of the theoretical density)	10.96
Maximum initial enrichment ( <sup>235</sup> U/U <sub>total</sub> ) (%)	5
Maximum mass ratio <sup>232</sup> U/U <sub>total</sub> (%)	5x10 <sup>-6</sup>   5x10 <sup>-8</sup>
Maximum mass ratio <sup>234</sup> U/U <sub>total</sub> (%)	0.30   0.055
Maximum mass ratio <sup>236</sup> U/U <sub>total</sub> (%)	4   0.05
Maximum absolute internal pressure of fuel rods at 20 °C (in bar)	32.7
<p>(1) This number of rods corresponds to the maximum number of rods that can be inserted into a structure (assembly skeleton or quiver), including in the guide tubes.</p> <p>(2) ERU/ENU: Enriched Reprocessed Uranium / Enriched Natural Uranium.</p>	

Glycerine residues up to a maximum of 5 grams can be present on the fuel assemblies.

The mechanical strength properties of the fuel rod cladding material meet one of the following two triplets:

	1	2
<b>R<sub>p0.2</sub> (MPa)</b>	≥ 520	≥ 250
<b>R<sub>m</sub> (MPa)</b>	≥ 710	≥ 400
<b>A<sub>t</sub> (% over 50 mm)</b>	≥ 12	≥ 25

Maximum activity per packaging: 0.655 TBq in case of ERU.

Material classification: LSA II for ENU fuel rods.  
LSA III for ERU fuel rods.

Physical state: Fuel rod assemblies composed of sintered pellets in a Zirconium alloy cladding, which may be pre-oxidised. The cladding can be covered with a layer of chromium up to 30 µm thick.

Chemical form: Uranium oxide (UO<sub>2</sub>) pellets and/or fuel pellets composed of a mixture of UO<sub>2</sub> and a body that acts as a neutron poison. The pellets may contain chromium oxide (but no other doping agents).

Special form: The material transported is not in any special form.

## 2. LOADING CONDITIONS

All assemblies in a load meet the conditions defined in the following table:

Maximum initial enrichment per fuel rod for each assembly in the load ( <sup>235</sup> U/U <sub>total</sub> )	Minimum number of fuel rods per fuel assembly in the load <sup>(1)</sup>
5 %	179
(1) Incomplete UO <sub>2</sub> fuel rod assemblies can be supplemented with gadolinium-carrying rods, rods containing depleted uranium or other metallic material, or bars filled with a metallic material (excluding graphite and beryllium), possibly containing a neutron poison. These supplementary rods or bars will be equivalent in size to the UO <sub>2</sub> rods. The expression "number of rods per assembly" is understood to mean the total number of fuel rods and replacement rods or bars.	

All fuel assemblies in the load, except one, can be replaced by fuel assembly skeletons.

The presence of desiccant is permitted.

The presence of materials with more hydrogen content than water is not authorised within the packaging.

## 3. SUB-CRITICALITY CONTINUITY

Sub-criticality continuity is covered in Chapter 2.5-3 of the safety analysis report.

The isolation system under consideration comprises the following elements:

- the characteristics of the fuel assemblies as described in the Table in Chapter 1 of this Appendix;
- the cladding tubes which guarantee the containment of the fissile material in an accident situation;
- the structure of the assembly (grids, end-pieces).

Criticality Safety Index (CSI): 0 (Number N = infinity).

**ANNEXE 5**  
**CONTENT NO. 5**  
**PWR TYPE 17 X 17 TWELVE-FOOT FUEL RODS**

The safety analysis report justifying the authorised content is report DOS-18-016471-000 Rev. 5.0.  
This content is loaded into a version 1 FCC3 packaging.

**1. DEFINITION OF AUTHORISED RADIOACTIVE CONTENT**

The authorised radioactive content, which are described in Chapter 1.3 of safety analysis report DOS-18-016471-006 Rev. 4.0, consist of a maximum of 2 boxes containing new fuel rods for pressurised water reactors (PWR), as described below:

Characteristics of fuel rods		
Type of assembly array housing these rods	17 x 17 twelve foot	
Maximum total mass per cavity (kg)	751	
Maximum total mass of the rods per box (kg)	461	
Maximum mass of UO <sub>2</sub> (kg)	380/box	
Nominal active length (mm)	3,658	
Maximum number of fuel rods per box	185	
Cladding material	Zirconium alloy, possibly pre-oxidised, possibly chromium-plated	
Minimum metal thickness (mm)	0.52	
Minimum outer diameter (mm)	9.40	
Pellets:	ERU <sup>(2)</sup>	ENU <sup>(2)</sup>
Maximum diameter (mm)	8.30	
Maximum oxide density (100% of the theoretical density)	10.96	
Maximum initial enrichment ( <sup>235</sup> U/U <sub>total</sub> ) (%)	5	
Maximum mass ratio <sup>232</sup> U/U <sub>total</sub> (%)	5x10 <sup>-6</sup>	5x10 <sup>-8</sup>
Maximum mass ratio <sup>234</sup> U/U <sub>total</sub> (%)	0.30	0.055
Maximum mass ratio <sup>236</sup> U/U <sub>total</sub> (%)	4	0.05
Minimum Gd <sub>2</sub> O <sub>3</sub> mass content in gadolinium-carrying rods (%) <sup>(1)</sup>	2	
Maximum absolute internal pressure of fuel rods at 20 °C (in bar)	32.7	
<sup>(1)</sup> Fuel rods with a Gd <sub>2</sub> O <sub>3</sub> content of less than 2% are considered as (non gadolinium-carrying) UO <sub>2</sub> fuel rods.		
<sup>(2)</sup> ERU / ENU: Enriched Reprocessed Uranium / Enriched Natural Uranium.		

The mechanical strength properties of the fuel rod cladding material meet one of the following triplets:

	<b>1</b>	<b>2</b>
<b>R<sub>p0.2</sub> (MPa)</b>	≥ 520	≥ 250
<b>R<sub>m</sub> (MPa)</b>	≥ 710	≥ 400
<b>A<sub>t</sub> (% over 50 mm)</b>	≥ 12	≥ 25

Maximum activity per packaging: 0.570 TBq in case of ERU.

Material classification: LSA II for ENU fuel rods  
LSA III for ERU fuel rods

Physical state: Fuel rods composed of sintered pellets in a Zirconium alloy cladding, which may be pre-oxidised. The cladding can be covered with a layer of chromium up to 30 µm thick.

Chemical form: Uranium oxide (UO<sub>2</sub>) pellets and/or fuel pellets composed of a mixture of UO<sub>2</sub> and a body that acts as a neutron poison. The pellets may contain chromium oxide (but no other doping agents).

Special form: The material transported is not in any special form.

## 2. **LOADING CONDITIONS**

All fuel rods in a load meet the conditions defined in the following table:

Maximum initial enrichment of each fuel rod in the load ( $^{235}\text{U}/\text{U}_{\text{total}}$ )	Minimum number of fuel rods per box <sup>(1)</sup>
5 %	Full row of fuel or inert rods
<sup>(1)</sup> Incomplete rows of fuel rods must be supplemented with solid stainless steel (or zirconium alloy) bars, with a nominal diameter of between 9.5 mm and 10 mm, possibly containing a neutron poison.	

The presence of desiccant is permitted.

The presence of materials with more hydrogen content than water is not authorised within the packaging.

## 3. **INTERNAL FITTINGS**

### 3.1 **Rod box**

The unassembled rods are grouped together in FCC3-type rod boxes, which are inserted in place of the assemblies inside the version 1 FCC3 packagings.

A rod box is made of a folded U-shaped sheet, which is closed at the ends and reinforced by two members welded to the top of the sheet.

A system of axial and radial spacers is used to adapt to the lengths of the rods and to hold them in position. A diagram is provided in Figure 5.1.

The minimum height of the radial spacer is 85 mm.

### 3.2 **Rod box spacers**

A set of 2 spacers longitudinally holds the box in place in the cavity (a top spacer and a bottom spacer). A detailed description of the spacers can be found in Chapter 1.3-1 of the safety analysis report.

#### 4. SUB-CRITICALITY CONTINUITY

Sub-criticality continuity is covered in Chapter 2.5-2 of the safety analysis report.

The “content” part of the isolation system under consideration comprises the following elements:

- the characteristics of the fuel rods as described in the table in Chapter 1 of this Appendix;
- the cladding tubes which guarantee the containment of the fissile material in an accident situation.

Criticality Safety Index (CSI):

- when  $\text{UO}_2$  rods are transported, the criticality safety index is equal to 0 (number N = infinity);
- when  $\text{UO}_2\text{-Gd}_2\text{O}_3$  rods are transported, the criticality safety index is 0 (number N = infinity).

**FIGURE 5.1**  
**DIAGRAM OF THE RODS BOX**

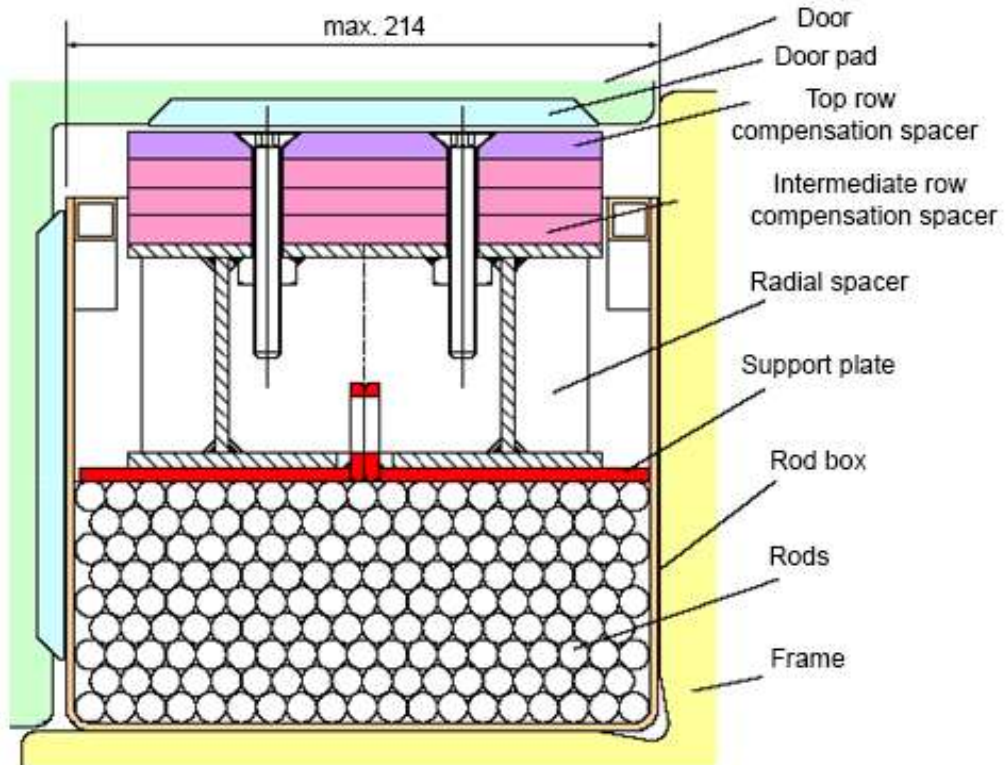

**ANNEXE 6**  
**CONTENT NO. 6**  
**PWR TYPE 15 X 15 FUEL RODS**

The safety analysis report justifying the authorised content is report DOS-18-016471-000 Rev. 5.0.  
This content is loaded into a version 1 FCC3 packaging.

**1. DEFINITION OF AUTHORISED RADIOACTIVE CONTENT**

The authorised radioactive content, which are described in Chapter 1.3 of safety analysis report DOS-18-016471-006 Rev. 4.0, consist of new fuel rods for pressurised water reactors (PWR), as described below:

<b>Characteristics of fuel rods</b>		
Type of assembly array housing these rods	15 x 15	
Maximum total mass per cavity (kg)	751	
Maximum total mass of the rods per box (kg)	470	
Maximum mass of UO <sub>2</sub> (kg)	389/box	
Nominal active length (mm)	3,658	
Maximum number of fuel rods per box	148	
Cladding material	Zirconium alloy, possibly pre-oxidised, possibly chromium-plated	
Minimum metal thickness (mm)	0.57	
Minimum outer diameter (mm)	10.68	
Pellets:	ERU (2)	ENU (2)
Maximum diameter (mm)	9.40	
Maximum oxide density (100% of the theoretical density)	10.96	
Maximum initial enrichment ( <sup>235</sup> U/U <sub>total</sub> ) (%)	5	
Maximum mass ratio <sup>232</sup> U/U <sub>total</sub> (%)	5x10 <sup>-6</sup>	5x10 <sup>-8</sup>
Maximum mass ratio <sup>234</sup> U/U <sub>total</sub> (%)	0.30	0.055
Maximum mass ratio <sup>236</sup> U/U <sub>total</sub> (%)	4	0.05
Minimum Gd <sub>2</sub> O <sub>3</sub> mass content in gadolinium-carrying rods (%) (1)	2	
Maximum absolute internal pressure of fuel rods at 20 °C (in bar)	32.7	
(1) Fuel rods with a Gd <sub>2</sub> O <sub>3</sub> content of less than 2% are considered as (non gadolinium-carrying) UO <sub>2</sub> fuel rods.		
(2) ERU/ENU: Enriched Reprocessed Uranium / Enriched Natural Uranium.		

The mechanical strength properties of the fuel rod cladding material meet one of the following two triplets:

	1	2
<b>R<sub>p0.2</sub> (MPa)</b>	≥ 520	≥ 250
<b>R<sub>m</sub> (MPa)</b>	≥ 710	≥ 400
<b>A<sub>t</sub> (% over 50 mm)</b>	≥ 12	≥ 25

Maximum activity per packaging: 0.584 TBq in case of ERU.

Material classification: LSA II for ENU fuel rods.  
LSA III for ERU fuel rods.

Physical state: Fuel rods composed of sintered pellets in a Zirconium alloy cladding, which may be pre-oxidised. The cladding can be covered with a layer of chromium up to 30 µm thick.

Chemical form: Uranium oxide (UO<sub>2</sub>) pellets and/or fuel pellets composed of a mixture of UO<sub>2</sub> and a body that acts as a neutron poison. The pellets may contain chromium oxide (but no other doping agents).

Special form: The material transported is not in any special form.

## 2. **LOADING CONDITIONS**

All fuel rods in a load meet the conditions defined in the following table:

Maximum initial enrichment of each fuel rod in the load ( <sup>235</sup> U/U <sub>total</sub> )	Minimum number of fuel rods per box <sup>(1)</sup>
5 %	Full row of fuel or inert rods
<sup>(1)</sup> Incomplete rows of fuel rods must be supplemented with solid stainless steel (or zirconium alloy) bars, with a nominal diameter of between 10.7 mm and 11 mm, possibly containing a neutron poison.	

The presence of desiccant is permitted.

The presence of materials with more hydrogen content than water is not authorised within the packaging.

## 3. **INTERNAL FITTINGS**

The internal fitting is a rod box, which is described in Chapters 1.3-1 and 1.3-2 of the safety analysis report.

### 3.1 **Rod box**

The unassembled rods are grouped together in FCC3-type rod boxes, which are inserted in place of the assemblies inside the version 1 FCC3's.

The box is made of a folded U-shaped sheet, which is closed at the ends and reinforced by two members welded to the top of the sheet.

A system of axial and radial spacers is used to adapt to the lengths of the rods and to hold them in position. A diagram is provided in Figure 6.1.

The minimum height of the radial spacer is 85 mm.

### 3.2 **Rod box spacers**

A set of 2 spacers longitudinally holds the box in place in the cavity (a top spacer and a bottom spacer). A detailed description of the spacers can be found in Chapter 1.3-1 of the safety analysis report.

#### 4. SUB-CRITICALITY CONTINUITY

Sub-criticality continuity is covered in Chapter 2.5-2 of the safety analysis report.

The “content” part of the isolation system under consideration comprises the following elements:

- the characteristics of the fuel rods as described in the table in Chapter 1 of this Appendix;
- the cladding tubes which guarantee the containment of the fissile material in an accident situation.

Criticality Safety Index (CSI):

- when  $\text{UO}_2$  rods are transported, the criticality safety index is equal to 0 (number N = infinity);
- when  $\text{UO}_2\text{-Gd}_2\text{O}_3$  rods are transported, the criticality safety index is 0 (number N = infinity).

**FIGURE 6.1**  
**DIAGRAM OF THE RODS BOX**

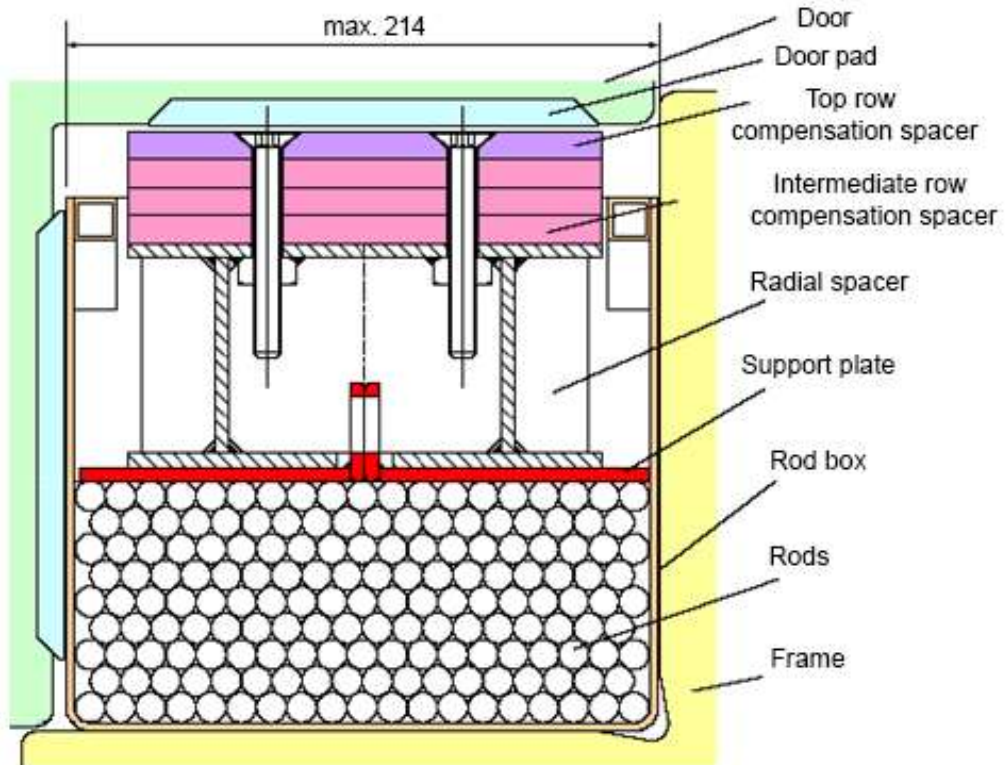

**ANNEXE 7**  
**CONTENT NO. 7**  
**PWR TYPE 14 X 14 EIGHT-FOOT FUEL RODS**

The safety analysis report justifying the authorised content is report DOS-18-016471-000 Rev. 5.0.  
This content is loaded into a version 1 FCC3 packaging.

**1. DEFINITION OF AUTHORISED RADIOACTIVE CONTENT**

The authorised radioactive content, which are described in Chapter 1.3 of safety analysis report DOS-18-016471-006 Rev. 4.0, consist of new fuel rods for pressurised water reactors (PWR), as described below:

<b>Characteristics of fuel rods</b>		
Type of assembly array housing these rods	14 x 14 eight foot	
Maximum total mass per cavity (kg)	751	
Maximum total mass of the rods per box (kg)	433	
Maximum mass of UO <sub>2</sub> (kg)	362/box	
Nominal active length (mm)	2,413	
Maximum number of fuel rods per box	204	
Cladding material	Zirconium alloy, possibly pre-oxidised, possibly chromium-plated	
Minimum metal thickness (mm)	0.57	
Minimum outer diameter (mm)	10.68	
Pellets:	ERU <sup>(2)</sup>	ENU <sup>(2)</sup>
Maximum diameter (mm)	9.40	
Maximum oxide density (100% of the theoretical density)	10.96	
Maximum initial enrichment ( <sup>235</sup> U/U <sub>total</sub> ) (%)	5	
Maximum mass ratio <sup>232</sup> U/U <sub>total</sub> (%)	5x10 <sup>-6</sup>	5x10 <sup>-8</sup>
Maximum mass ratio <sup>234</sup> U/U <sub>total</sub> (%)	0.30	0.055
Maximum mass ratio <sup>236</sup> U/U <sub>total</sub> (%)	4	0.05
Minimum Gd <sub>2</sub> O <sub>3</sub> mass content in gadolinium-carrying rods (%) <sup>(1)</sup>	2	
Maximum absolute internal pressure of fuel rods at 20 °C (in bar)	32.7	
<p>(1) Fuel rods with a Gd<sub>2</sub>O<sub>3</sub> content of less than 2% are considered as (non gadolinium-carrying) UO<sub>2</sub> fuel rods.</p> <p>(2) ERU/ENU: Enriched Reprocessed Uranium / Enriched Natural Uranium.</p>		

The mechanical strength properties of the fuel rod cladding material meet one of the following two triplets:

	1	2
<b>R<sub>p0.2</sub> (MPa)</b>	≥ 520	≥ 250
<b>R<sub>m</sub> (MPa)</b>	≥ 710	≥ 400
<b>A<sub>t</sub> (% over 50 mm)</b>	≥ 12	≥ 25

Maximum activity per packaging: 0.591 TBq in case of ERU.

Material classification: LSA II for ENU fuel rods.

LSA III for ERU fuel rods.

Physical state: Fuel rods composed of sintered pellets in a Zirconium alloy cladding, which may be pre-oxidised. The cladding can be covered with a layer of chromium up to 30 µm thick.

Chemical form: Uranium oxide (UO<sub>2</sub>) pellets and/or fuel pellets composed of a mixture of UO<sub>2</sub> and a body that acts as a neutron poison. The pellets may contain chromium oxide (but no other doping agents).

Special form: The material transported is not in any special form.

## 2. **LOADING CONDITIONS**

All fuel rods in a load meet the conditions defined in the following table:

Maximum initial enrichment of each fuel rod in the load ( <sup>235</sup> U/U <sub>total</sub> )	Minimum number of fuel rods per box <sup>(1)</sup>
5 %	Full row of fuel or inert rods

(1) Incomplete rows of fuel rods must be supplemented with solid stainless steel (or zirconium alloy) bars, with a nominal diameter of between 10.7 mm and 11 mm, possibly containing a neutron poison. The term “number of rods per box” is understood to mean the total number of fuel rods and steel (or zirconium alloy) bars.

The presence of desiccant is permitted.

The presence of materials with more hydrogen content than water is not authorised within the packaging.

## 3. **INTERNAL FITTINGS**

The internal fitting is a rod box, which is described in Chapters 1.3-1 and 1.3-2 of the safety analysis report.

### 3.1 **Rod box**

The unassembled rods are grouped together in FCC3-type rod boxes, which are inserted in place of the assemblies inside the version 1 FCC3's.

The box is made of a folded U-shaped sheet, which is closed at the ends and reinforced by two members welded to the top of the sheet.

A system of axial and radial spacers is used to adapt to the lengths of the rods and to hold them in position. A diagram is provided in Figure 7.1.

The minimum height of the radial spacer is 85 mm.

### **3.2 Rod box spacers**

A set of 2 spacers longitudinally holds the box in place in the cavity (a top spacer and a bottom spacer). A detailed description of the spacers can be found in Chapter 1.3-1 of the safety analysis report.

## **4. SUB-CRITICALITY CONTINUITY**

Sub-criticality continuity is covered in Chapter 2.5-2 of the safety analysis report.

The “content” part of the isolation system under consideration comprises the following elements:

- the characteristics of the fuel rods as described in the table in Chapter 1 of this Appendix;
- the cladding tubes which guarantee the containment of the fissile material in an accident situation.

Criticality Safety Index (CSI):

- when  $\text{UO}_2$  rods are transported, the criticality safety index is equal to 0 (number N = infinity);
- when  $\text{UO}_2\text{-Gd}_2\text{O}_3$  rods are transported, the criticality safety index is 0 (number N = infinity).

**FIGURE 7.1**  
**DIAGRAM OF THE RODS BOX**

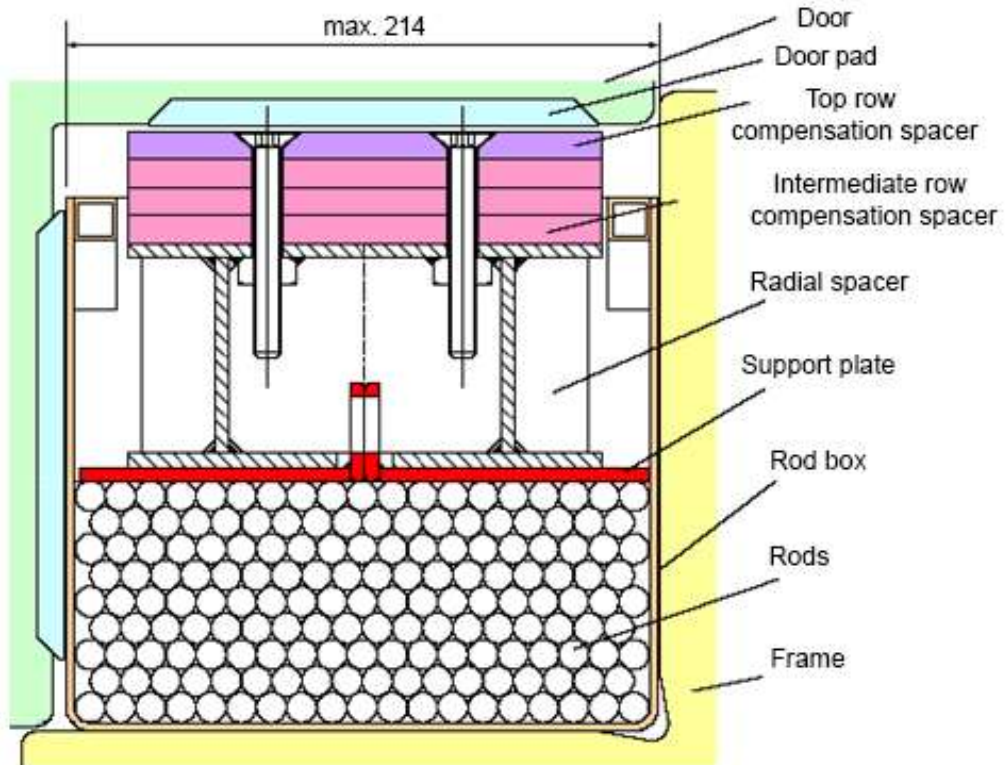

**ANNEXE 8**  
**CONTENT NO. 8**  
**PWR TYPE 14 X 14 TEN-FOOT FUEL RODS**

The safety analysis report justifying the authorised content is report DOS-18-016471-000 Rev. 5.0.  
This content is loaded into a version 1 FCC3 packaging.

**1. DEFINITION OF AUTHORISED RADIOACTIVE CONTENT**

The authorised radioactive content, which are described in Chapter 1.3 of safety analysis report DOS-18-016471-006 Rev. 4.0, consist of new fuel rods for pressurised water reactors (PWR), as described below:

<b>Characteristics of fuel rods</b>	
Type of assembly array housing these rods	14 x 14 ten foot
Maximum total mass per cavity (kg)	751
Maximum total mass of the rods per box (kg)	443
Maximum mass of UO <sub>2</sub> (kg)	374/box
Nominal active length (mm)	3,048
Maximum number of fuel rods per box	167
Cladding material	Zirconium alloy, possibly pre-oxidised, possibly chromium-plated
Minimum metal thickness (mm)	0.57
Minimum outer diameter (mm)	10.68
Pellets:	ERU <sup>(2)</sup>   ENU <sup>(2)</sup>
Maximum diameter (mm)	9.40
Maximum oxide density (100% of the theoretical density)	10.96
Maximum initial enrichment ( <sup>235</sup> U/U <sub>total</sub> ) (%)	5
Maximum mass ratio <sup>232</sup> U/U <sub>total</sub> (%)	5x10 <sup>-6</sup>   5x10 <sup>-8</sup>
Maximum mass ratio <sup>234</sup> U/U <sub>total</sub> (%)	0.30   0.055
Maximum mass ratio <sup>236</sup> U/U <sub>total</sub> (%)	4   0.05
Minimum Gd <sub>2</sub> O <sub>3</sub> mass content in gadolinium-carrying rods (%) <sup>(1)</sup>	2
Maximum absolute internal pressure of fuel rods at 20 °C (in bar)	32.7
<p>(1) Fuel rods with a Gd<sub>2</sub>O<sub>3</sub> content of less than 2% are considered as (non gadolinium-carrying) UO<sub>2</sub> fuel rods. (2) ERU/ENU: Enriched Reprocessed Uranium / Enriched Natural Uranium.</p>	

The mechanical strength properties of the fuel rod cladding material meet one of the following triplets:

	1	2
<b>R<sub>p0.2</sub> (MPa)</b>	≥ 520	≥ 250
<b>R<sub>m</sub> (MPa)</b>	≥ 710	≥ 400
<b>A<sub>t</sub> (% over 50 mm)</b>	≥ 12	≥ 25

Maximum activity per packaging: 0.562 TBq in case of ERU.

Material classification: LSA II for ENU fuel rods.

LSA III for ERU fuel rods.

Physical state: Fuel rods composed of sintered pellets in a Zirconium alloy cladding, which may be pre-oxidised. The cladding can be covered with a layer of chromium up to 30 µm thick.

Chemical form: Uranium oxide (UO<sub>2</sub>) pellets and/or fuel pellets composed of a mixture of UO<sub>2</sub> and a body that acts as a neutron poison. The pellets may contain chromium oxide (but no other doping agents).

Special form: The material transported is not in any special form.

## 2. **LOADING CONDITIONS**

All fuel rods in a load meet the conditions defined in the following table:

Maximum initial enrichment of each fuel rod in the load ( <sup>235</sup> U/U <sub>total</sub> )	Minimum number of fuel rods per box <sup>(1)</sup>
5 %	Full row of fuel or inert rods

(1) Incomplete rows of fuel rods must be supplemented with solid stainless steel (or zirconium alloy) bars, with a nominal diameter of between 10.7 mm and 11 mm, possibly containing a neutron poison. The term “*number of rods per box*” is understood to mean the total number of fuel rods and steel (or zirconium alloy) bars.

The presence of desiccant is permitted.

The presence of materials with more hydrogen content than water is not authorised within the packaging.

## 3. **INTERNAL FITTINGS**

The internal fitting is a rod box, which is described in Chapters 1.3-1 and 1.3-2 of the safety analysis report.

### 3.1 **Rod box**

The unassembled rods are grouped together in FCC3-type rod boxes, which are inserted in place of the assemblies inside the version 1 FCC3's.

The box is made of a folded U-shaped sheet, which is closed at the ends and reinforced by two members welded to the top of the sheet.

A system of axial and radial spacers is used to adapt to the lengths of the rods and to hold them in position. A diagram is provided in Figure 8.1.

The minimum height of the radial spacer is 85 mm.

### **3.2 Rod box spacers**

A set of 2 spacers longitudinally holds the box in place in the cavity (a top spacer and a bottom spacer). A detailed description of the spacers can be found in Chapter 1.3-1 of the safety analysis report.

## **4. SUB-CRITICALITY CONTINUITY**

Sub-criticality continuity is covered in Chapter 2.5-2 of the safety analysis report.

The “content” part of the isolation system under consideration comprises the following elements:

- the characteristics of the fuel rods as described in the table in Chapter 1 of this Appendix;
- the cladding tubes which guarantee the containment of the fissile material in an accident situation.

Criticality Safety Index (CSI):

- when  $\text{UO}_2$  rods are transported, the criticality safety index is equal to 0 (number N = infinity);
- when  $\text{UO}_2\text{-Gd}_2\text{O}_3$  rods are transported, the criticality safety index is 0 (number N = infinity).

**FIGURE 8.1**  
**DIAGRAM OF THE RODS BOX**

